

# CÓMODA NÓRDICA

## 6 CAJONES

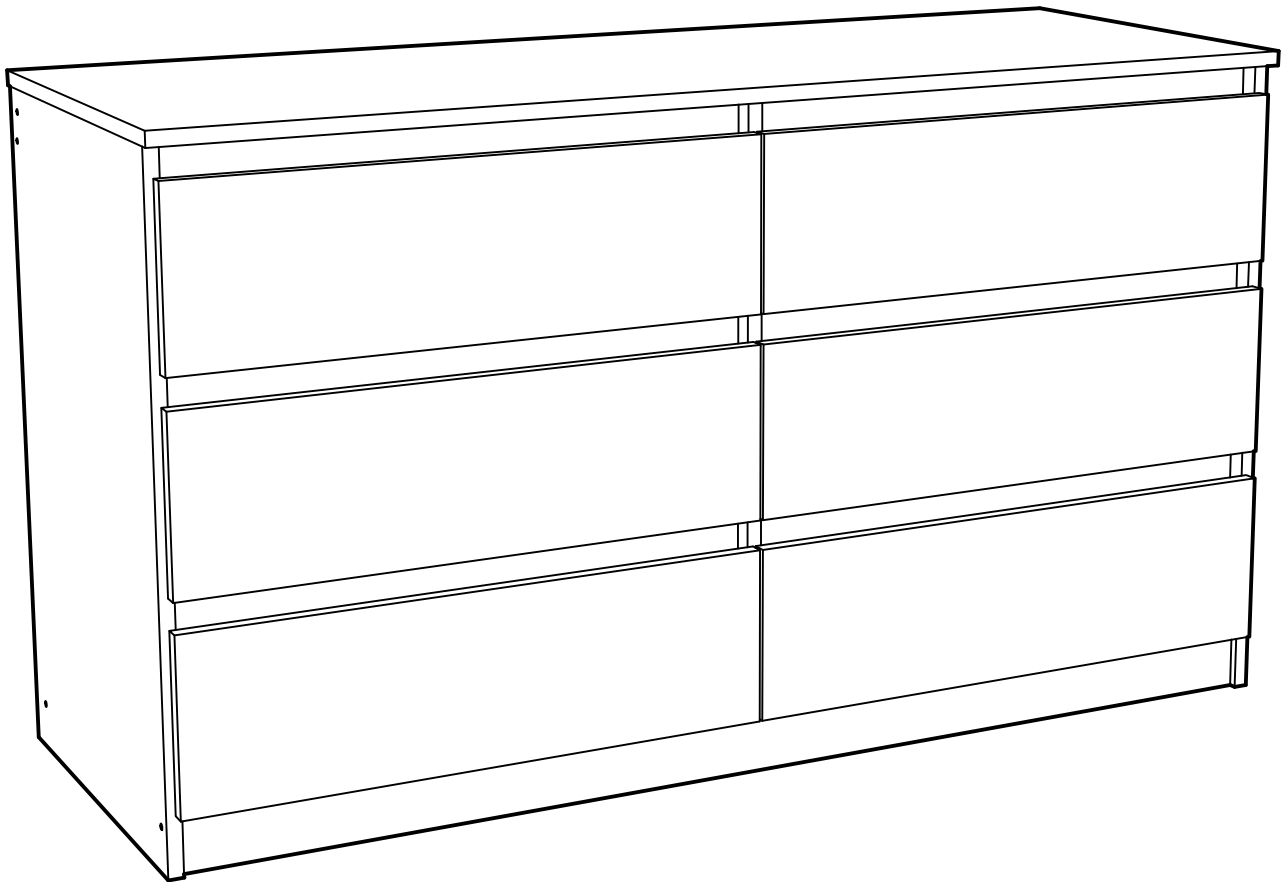

## Encuentre su Manual de Armado:

- 1- Ingrese a [www.cic.cl](http://www.cic.cl)
- 2- Busque el nombre del mueble.
- 3- Haga clic sobre el mueble seleccionado.
- 4- Digíjase a la opción "ARMALO TU MISMO".
- 5- Descargue el manual de armado.

o escanée el siguiente código QR.



## HERRAMIENTAS

A USAR · NO INCLUIDAS

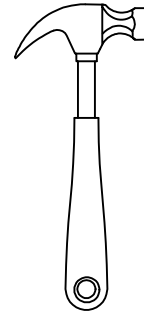
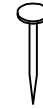
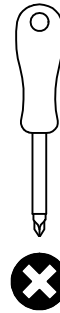

HUINCHA DE MEDIR

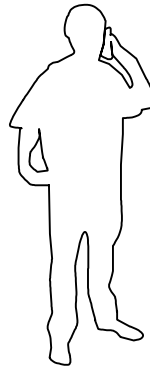
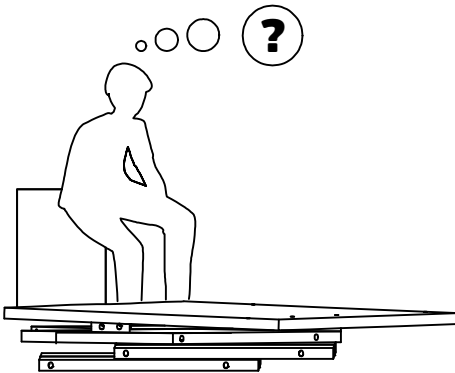
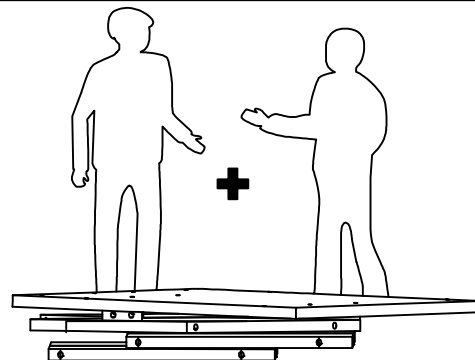
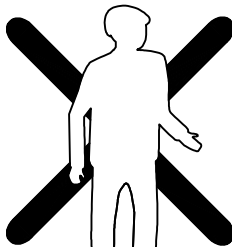

**SERVICIO AL CLIENTE**  
**800 74 00 00**

## INDICA TAPACANTO



- 1.- Revise que todos los herrajes contenido(s) en la(s) bolsa(s), coincidan con el listado de herrajes indicado en las siguientes páginas.
- 2.- No elimine ningún número de las piezas. Una vez armado el mueble puede desprenderlos y/o borrarlos (los números impresos puede borrarlos con alcohol, alcohol gel o desinfectante de ambientes).
- 3.- Revise que todos los herrajes de la(s) bolsa(s) coincidan con el listado que aparece en este instructivo (tipo de herraje y cantidad).
- 4.- No retire el número que va pegado en el exterior de la caja. Este número se denominacódigo de trazabilidad (ej.: 0871265) y tiene por objetivo hacer el seguimiento al mueble, en caso de que se presenten problemas en el armado.

# PIEZAS Y COMPONENTES

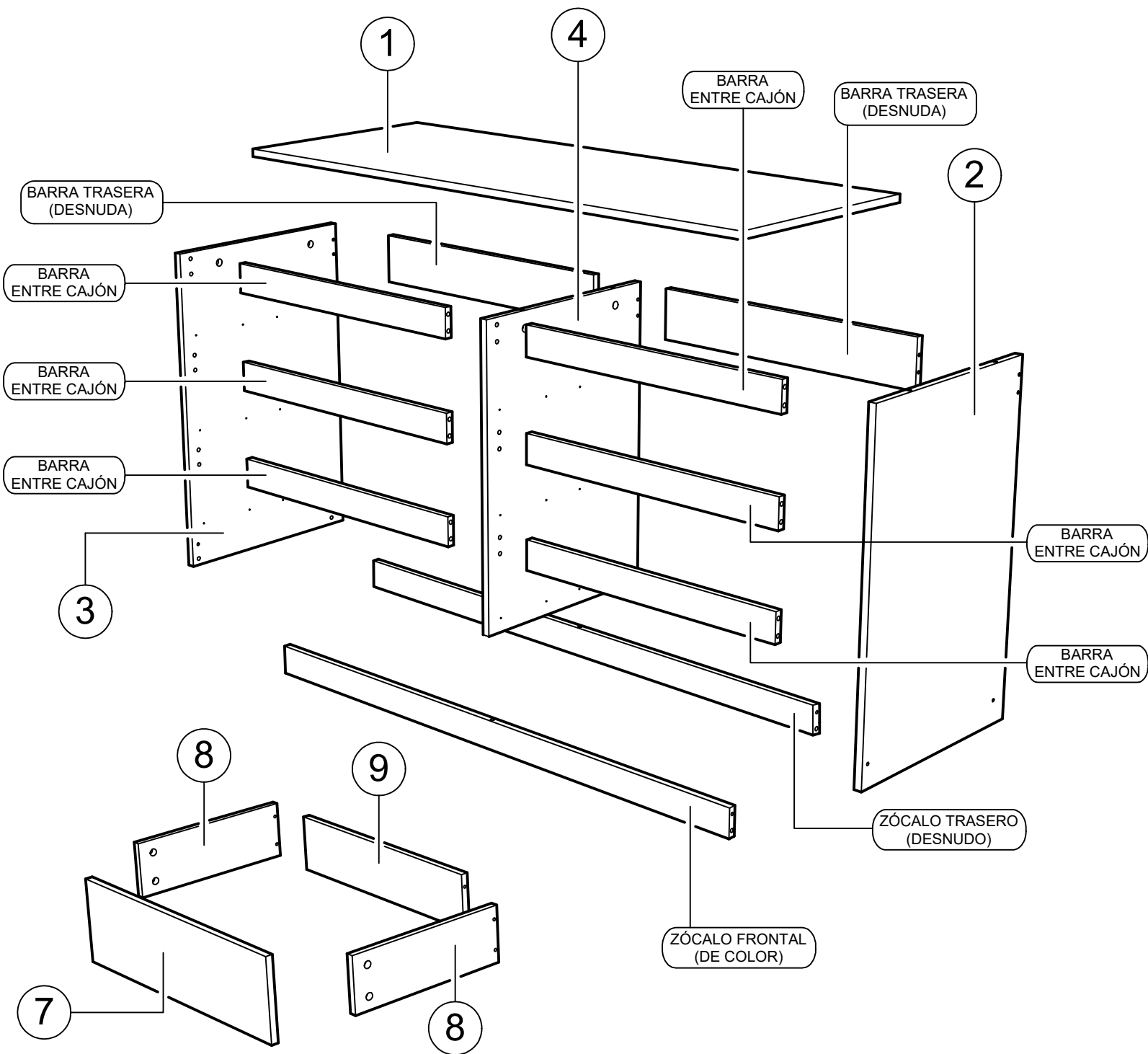

<b>1</b>	CUBIERTA	<b>x1</b>
<b>2</b>	COSTADO DERECHO	<b>x1</b>
<b>3</b>	COSTADO IZQUIERDO	<b>x1</b>
<b>4</b>	COSTADO CENTRAL	<b>x1</b>
<b>S/N</b>	BARRA ENTRE CAJÓN (58x6cm)	<b>x6</b>
<b>S/N</b>	ZÓCALO FRONTAL (118x6cm)	<b>x1</b>

<b>7</b>	FRENTE CAJÓN	<b>x6</b>
<b>8</b>	COSTADO CAJÓN	<b>x12</b>
<b>9</b>	TRASERA CAJÓN	<b>x6</b>
<b>S/N</b>	BARRA TRASERA (58x10cm)	<b>x2</b>
<b>S/N</b>	ZÓCALO TRASERO (118x6cm)	<b>x1</b>

# HERRAJES

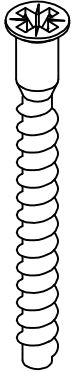

M x32



x8



x8

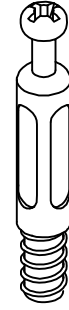

x30

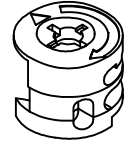

x34

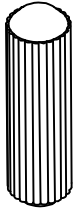

x30

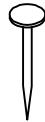

x90



C x60

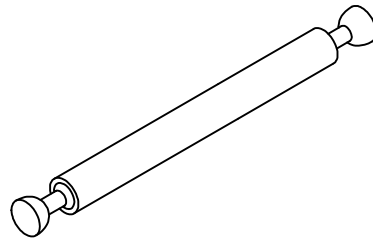

x2

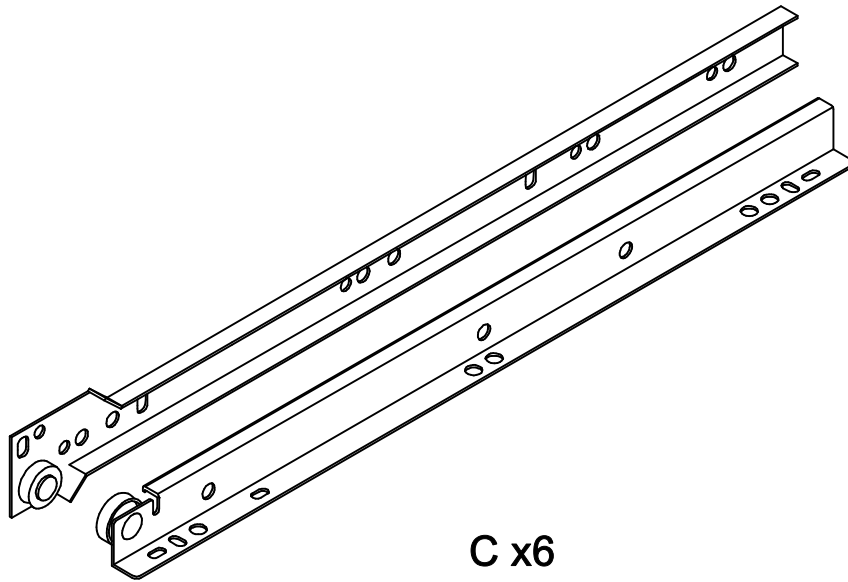

C x6



# PREPARACIÓN DE PIEZAS

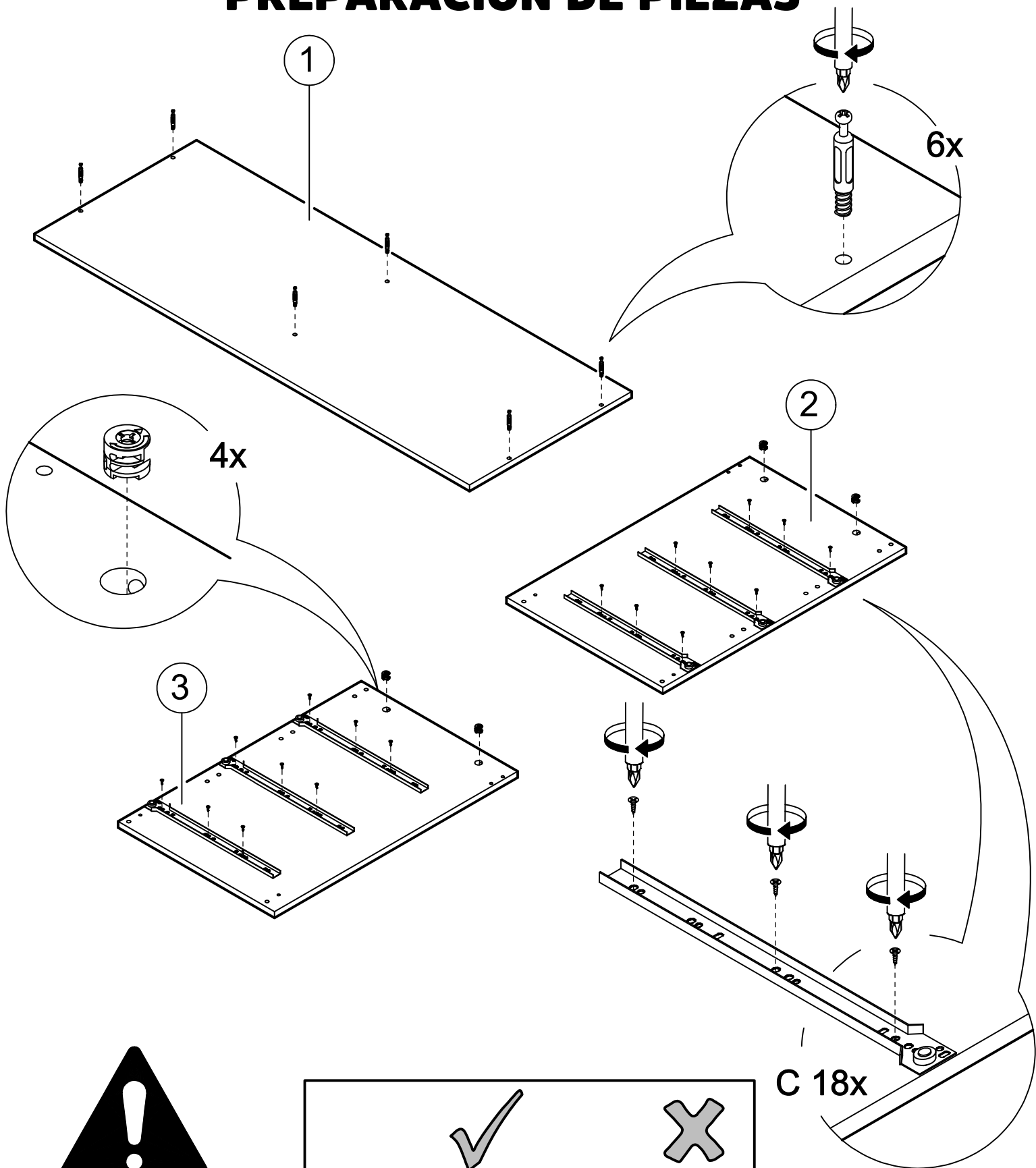

## PRECAUCIÓN

LA CABEZA DE LOS TORNILLOS DEBE QUEDAR ALINEADA CON LA CORREDERA. DE NO SER ASÍ, SE PRODUCIRÁ UN ROCE (RUIDO) AL ABRIR Y CERRAR EL CAJÓN.

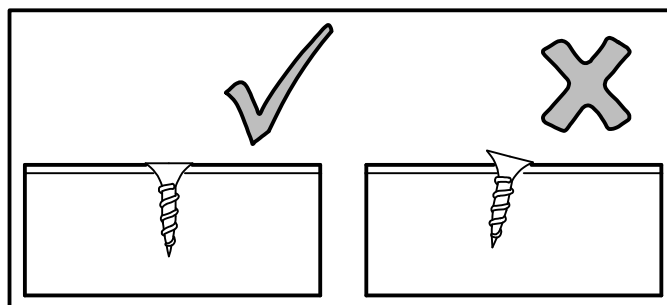

# PREPARACIÓN DE PIEZAS

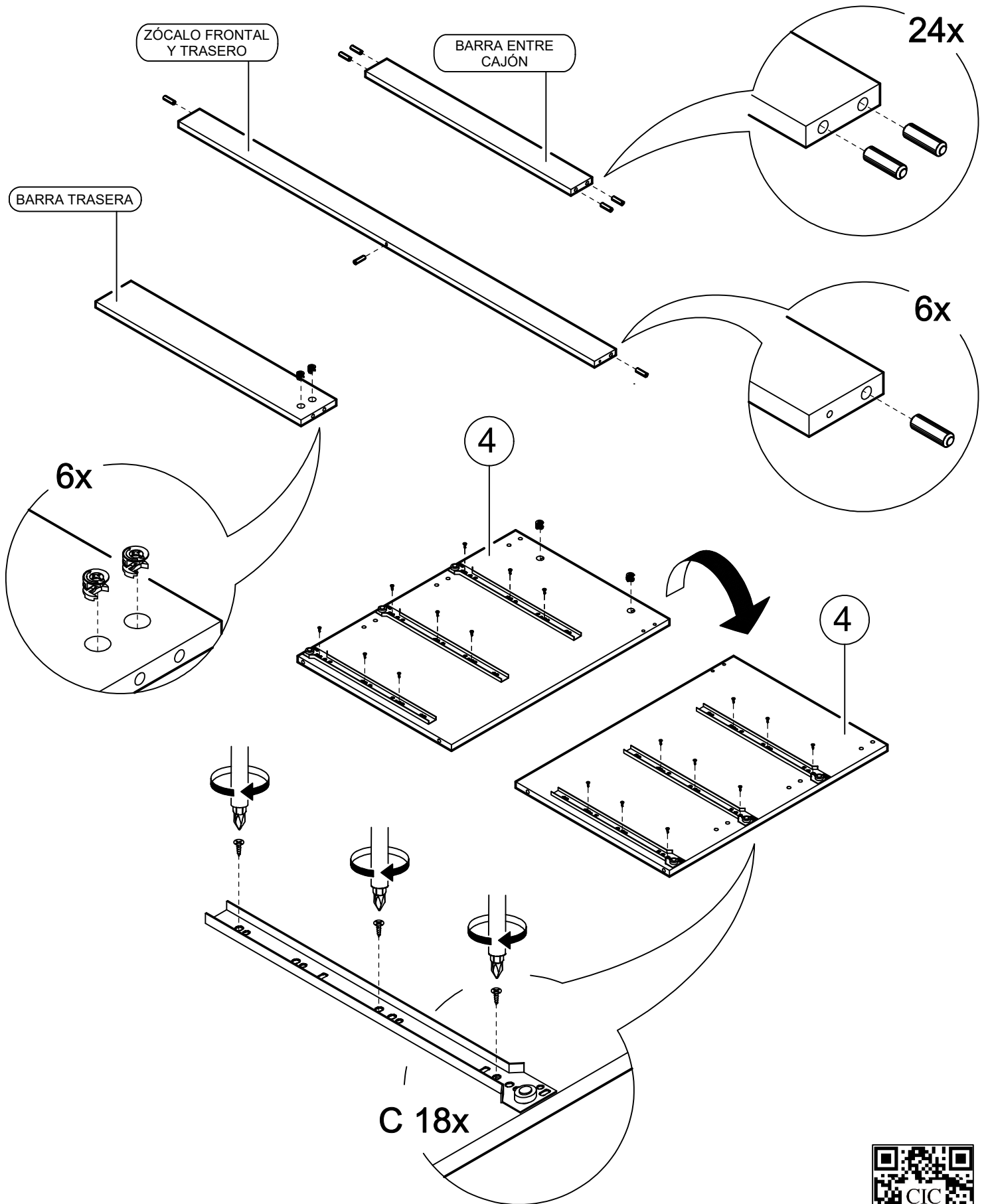

# SECUENCIA DE ARMADO

# 1

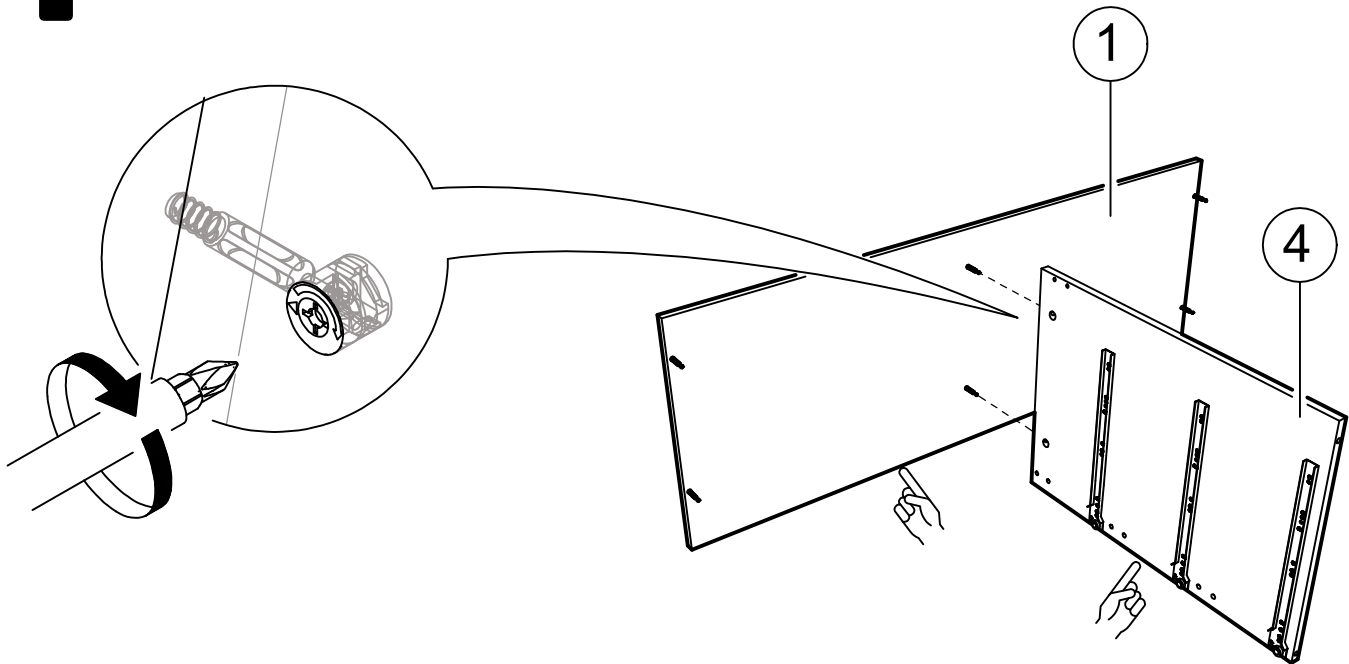

# 2

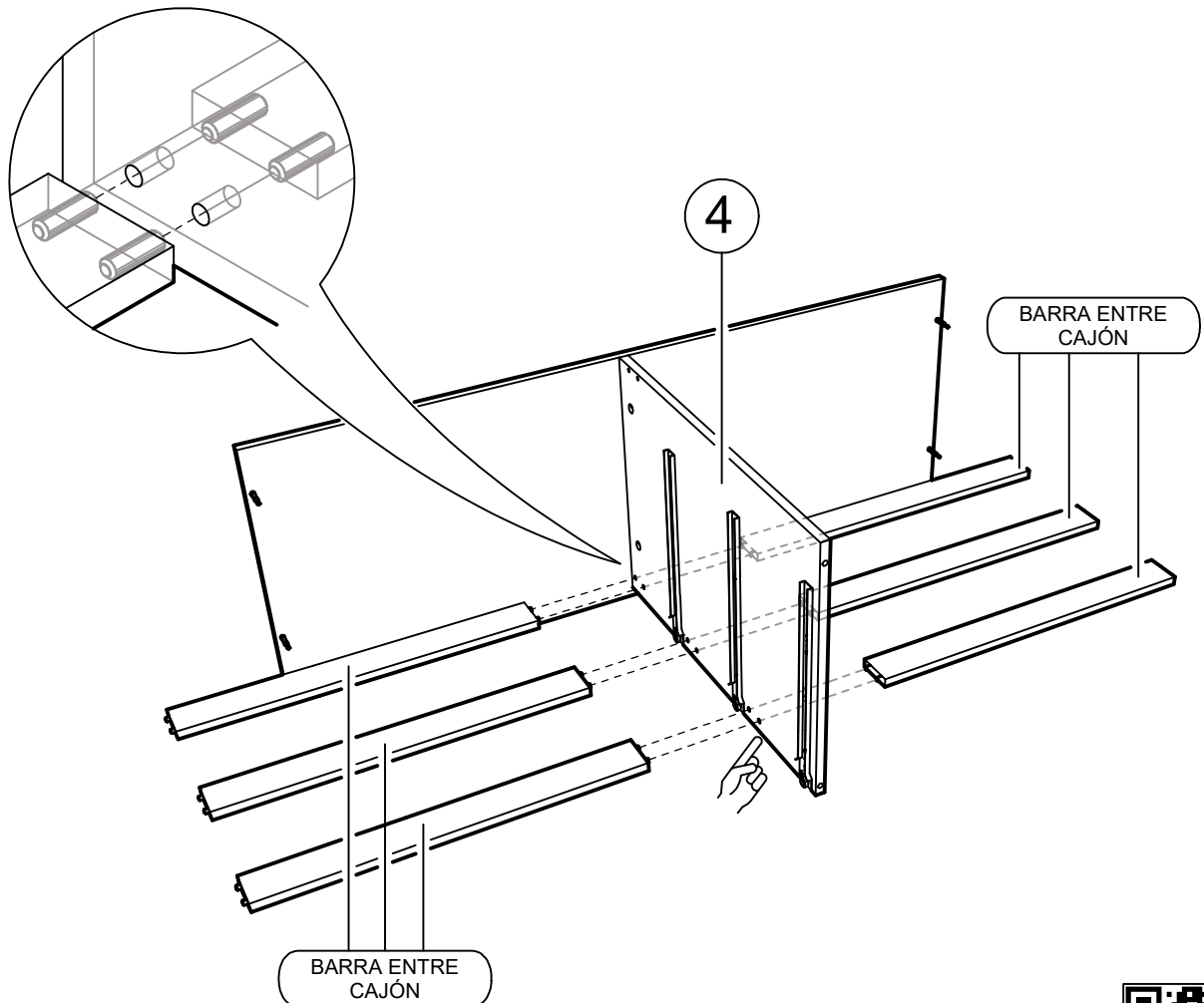

# 3



**PRECAUCIÓN**  
INSERTE LOS PERNOS  
CONECTORES DOBLES EN  
LAS PERFORACIONES DEL  
COSTADO CENTRAL.

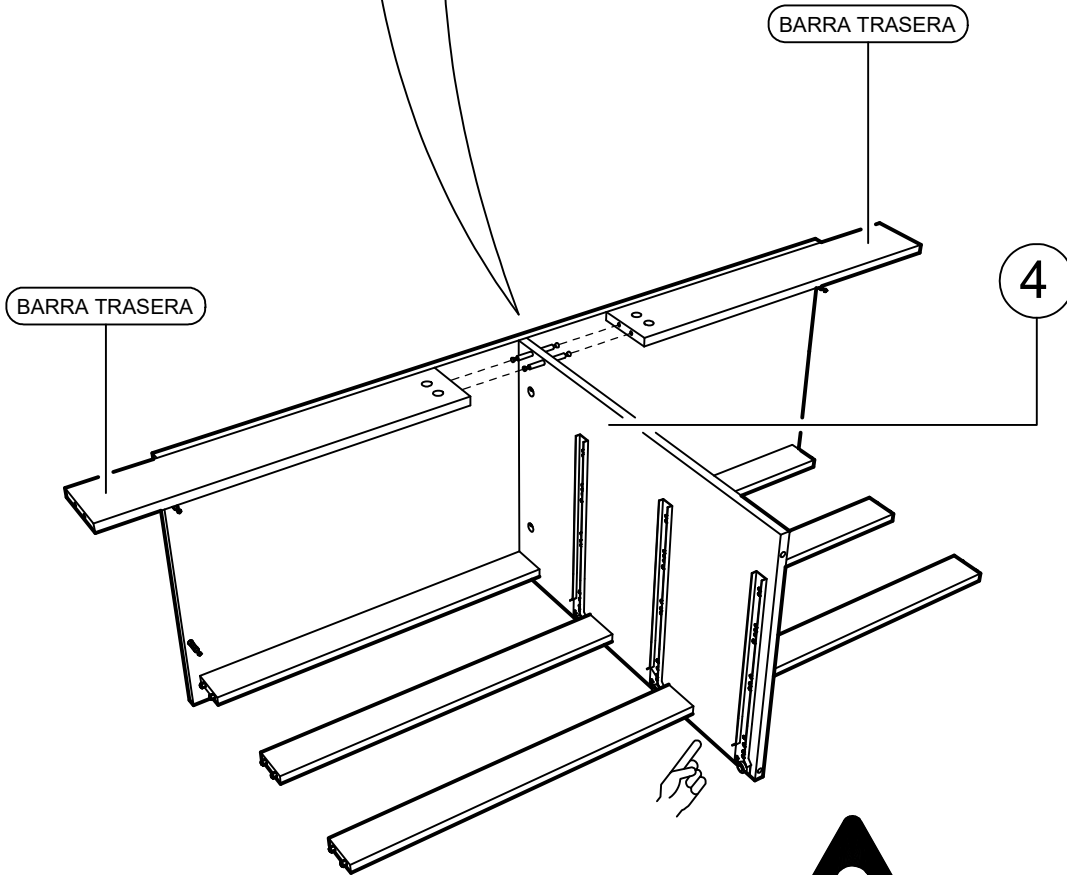
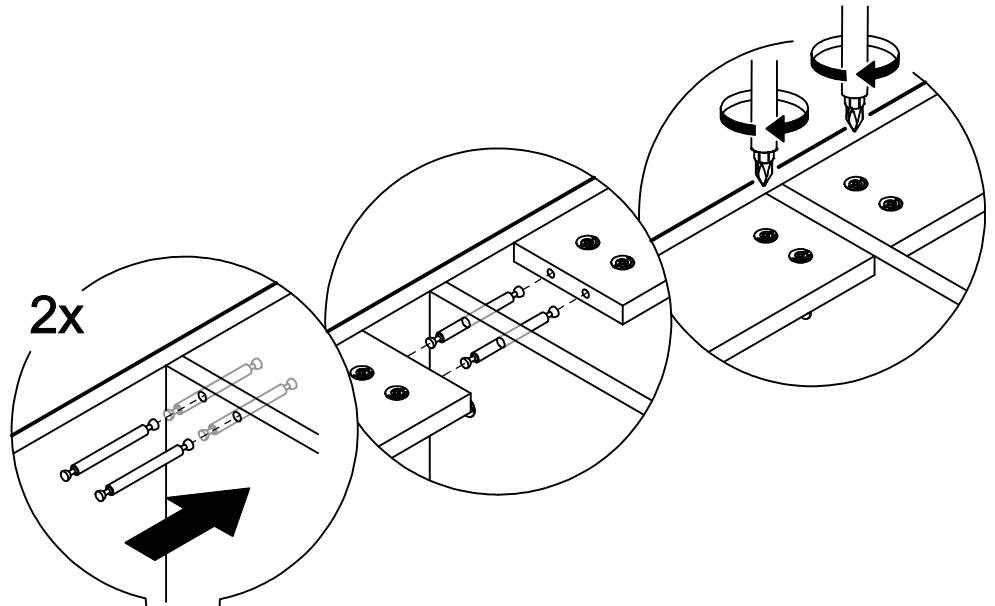

**PRECAUCIÓN**  
AYÚDESE DE OTRA  
PERSONA PARA MANTENER  
LAS BARRAS TRASERAS EN  
SU POSICIÓN.





# 4

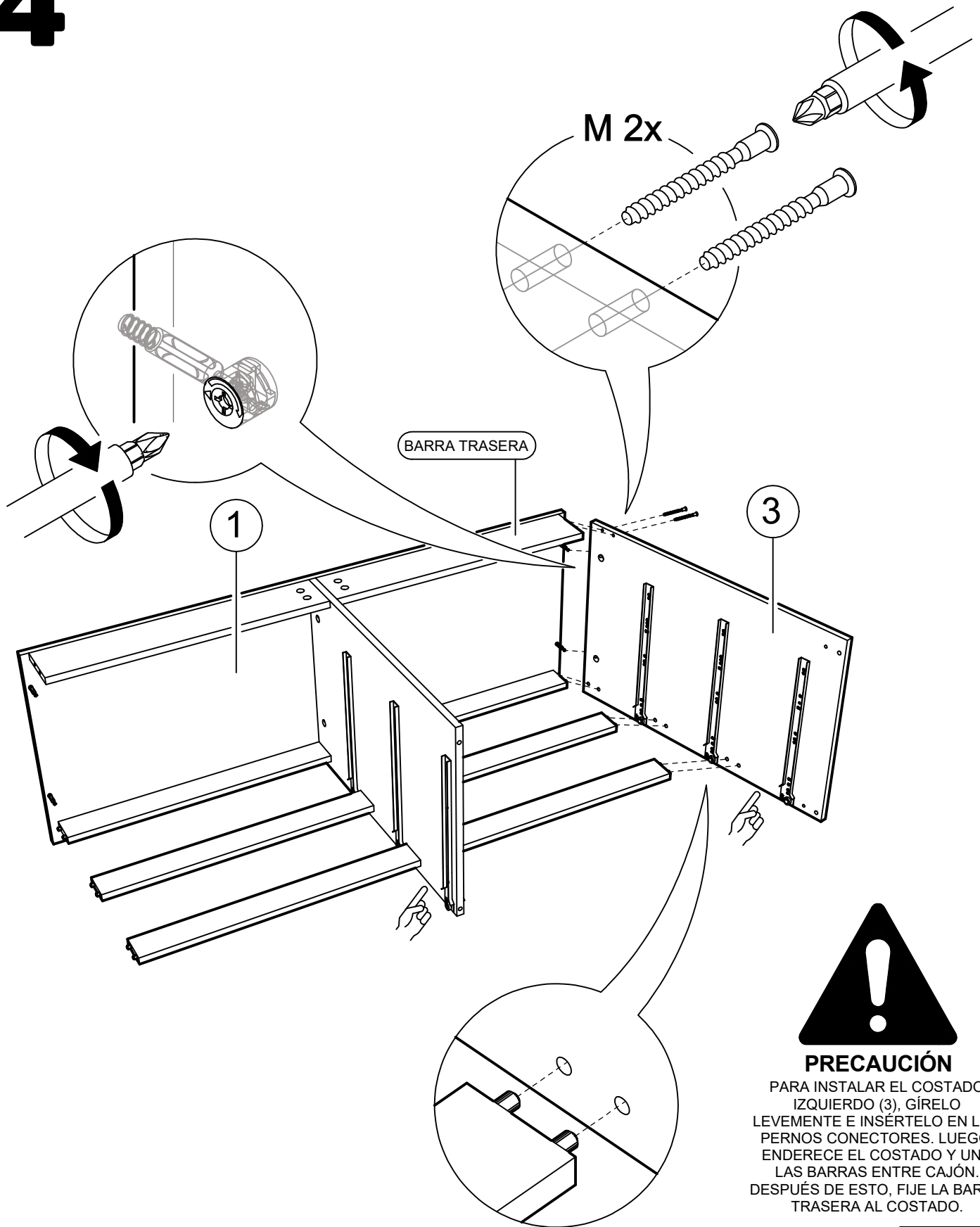

# 5

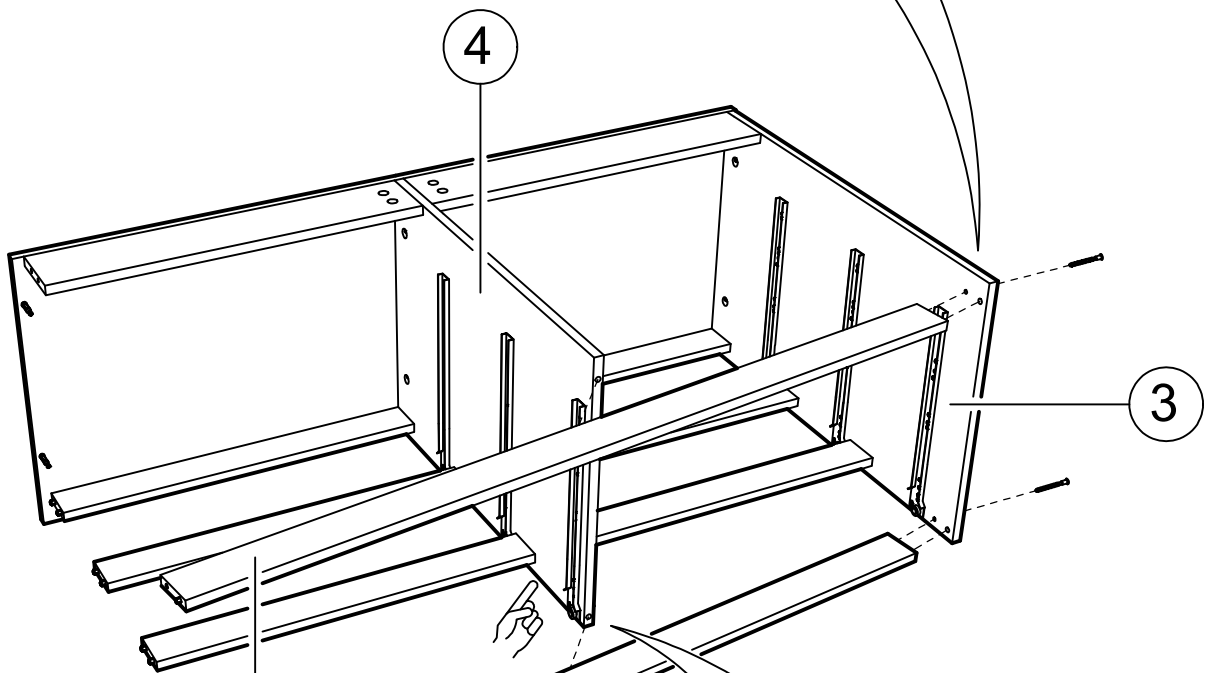
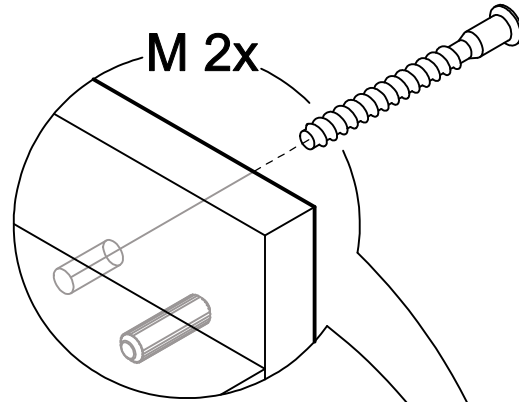
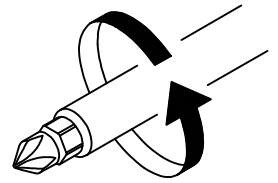

ZÓCALO TRASERO  
(DESNUDO)

ZÓCALO FRONTAL  
(DE COLOR)



**PRECAUCIÓN**

AYÚDESE DE OTRA  
PERSONA PARA MANTENER  
LOS ZÓCALOS EN SU POSICIÓN.



# 6



## PRECAUCIÓN

PARA INSTALAR EL COSTADO DERECHO (2), GÍRELO LEVEMENTE E INSÉRTELO EN LOS PERNOS CONECTORES. LUEGO, ENDERECE EL COSTADO Y UNA LAS BARRAS ENTRE CAJÓN Y LOS ZÓCALOS.

2

M 4x

BARRA TRASERA

ZÓCALO TRASERO (DESNUDO)

ZÓCALO FRONTAL (BLANCO)

M 2x



## PRECAUCIÓN

AYÚDESE DE OTRA PERSONA PARA MANTENER LOS ZÓCALOS EN SU POSICIÓN.



# 7



### PRECAUCIÓN

DEL TOTAL DE CLAVOS (90 UNIDADES), OCUPE 30 UNID. PARA FIJACIÓN DE LAS TRASERAS.

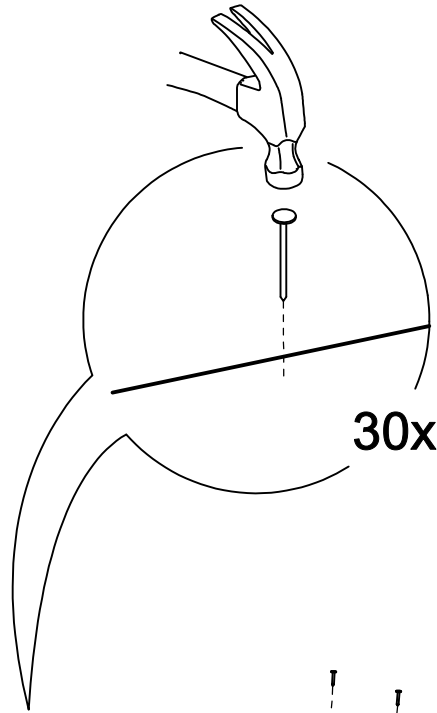

### PRECAUCIÓN

PRIMERAMENTE FIJE LA TRASERA SUPERIOR. ÉSTA DEBE QUEDAR CASI A RAS CON LA CUBIERTA. DESPUÉS, FIJE LA TRASERA INFERIOR, DEJÁNDOLA PEGADA A LA ANTERIOR.

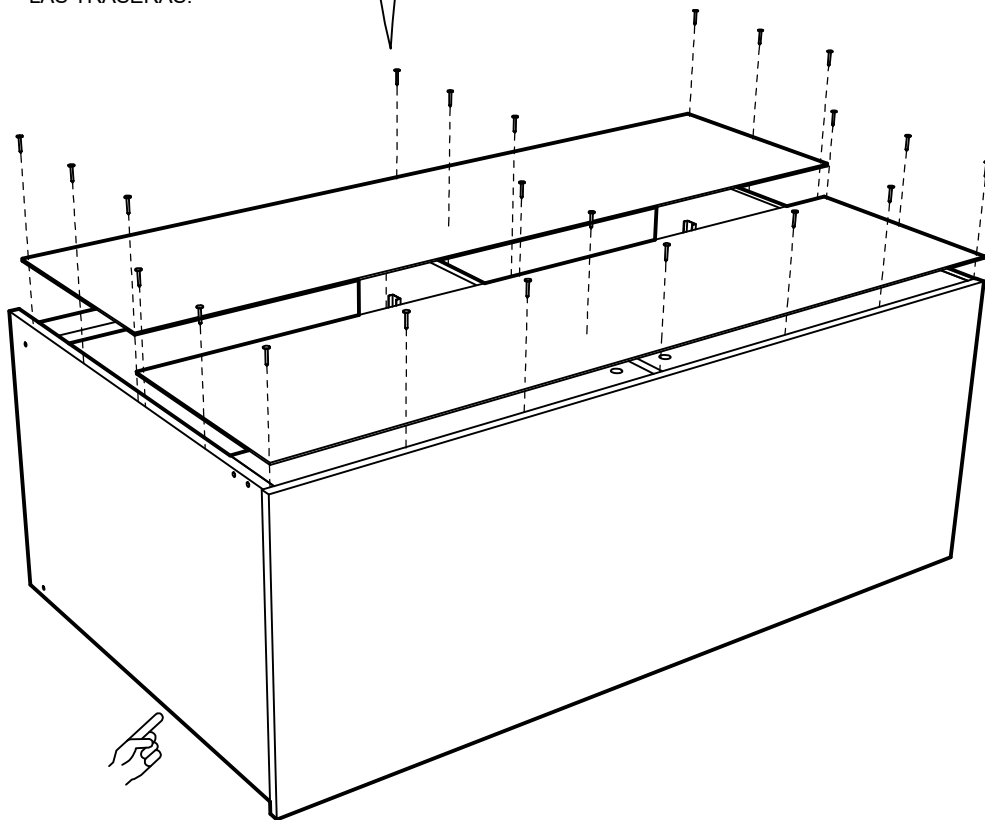

# 8

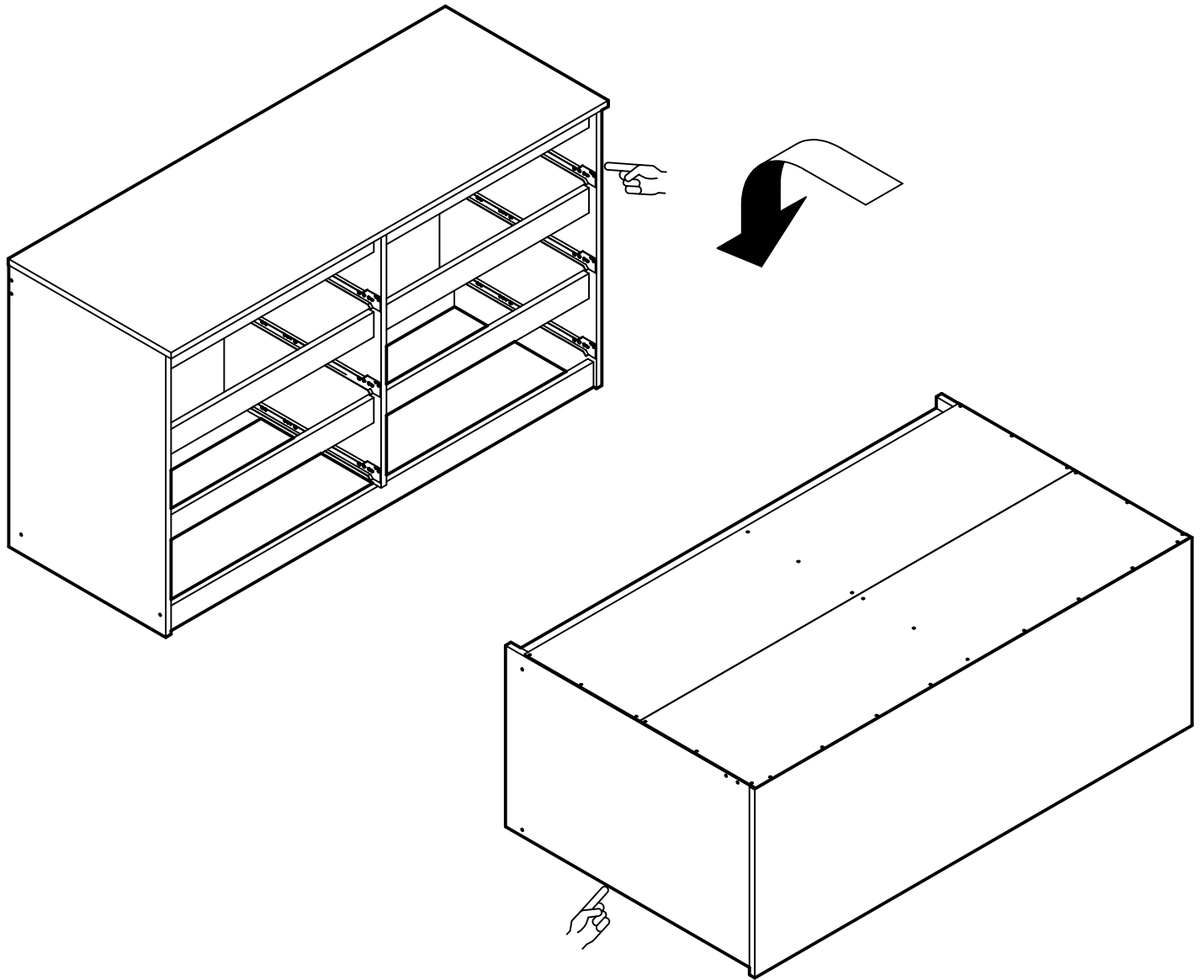

# 9

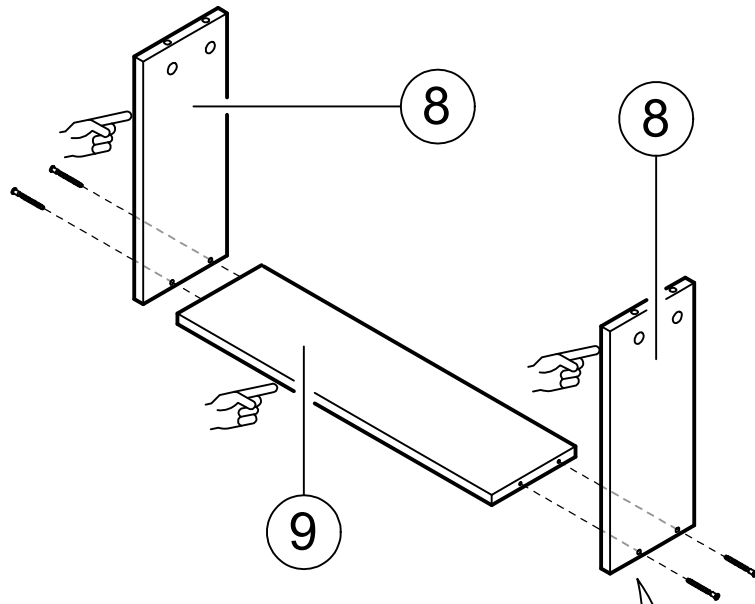

# 10

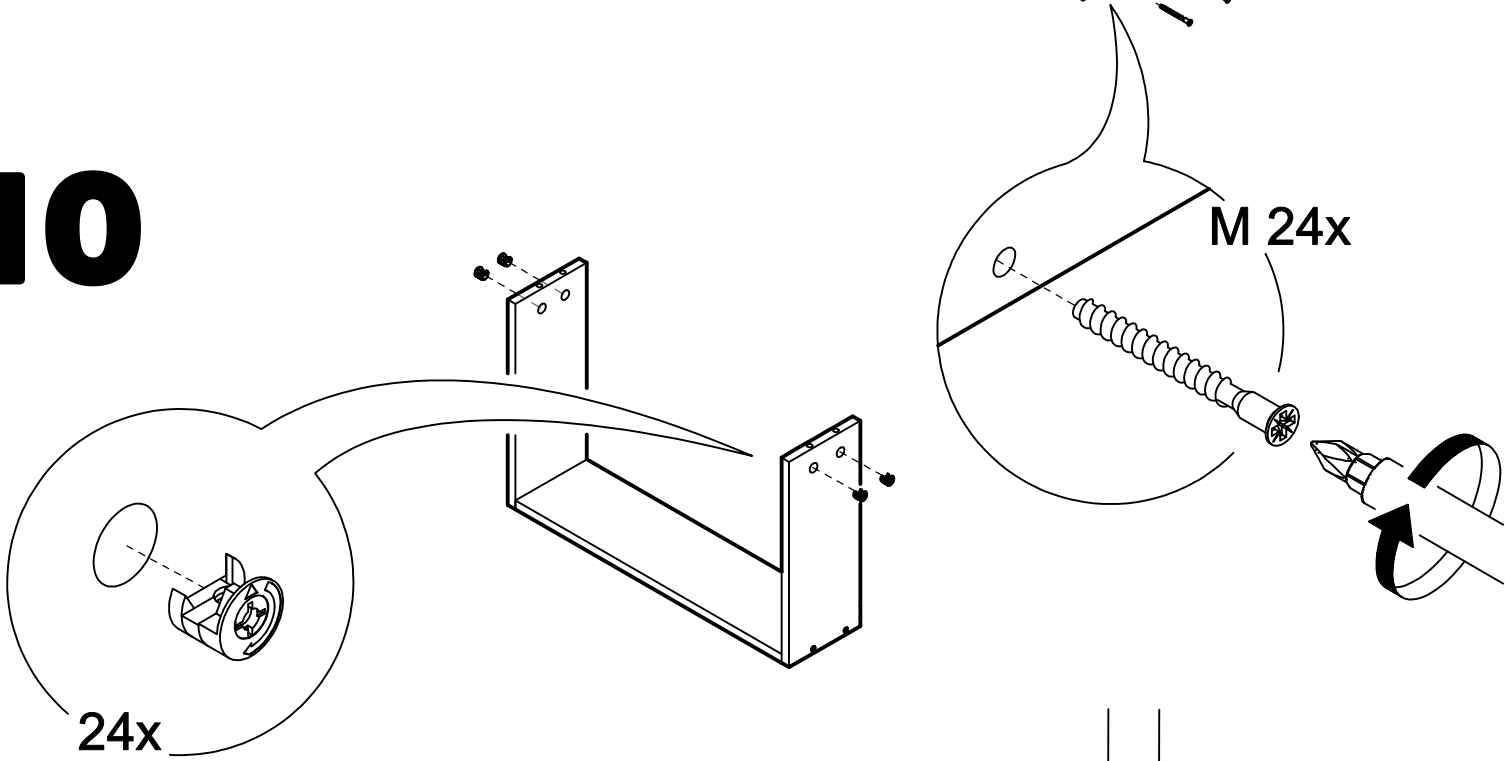

# 11

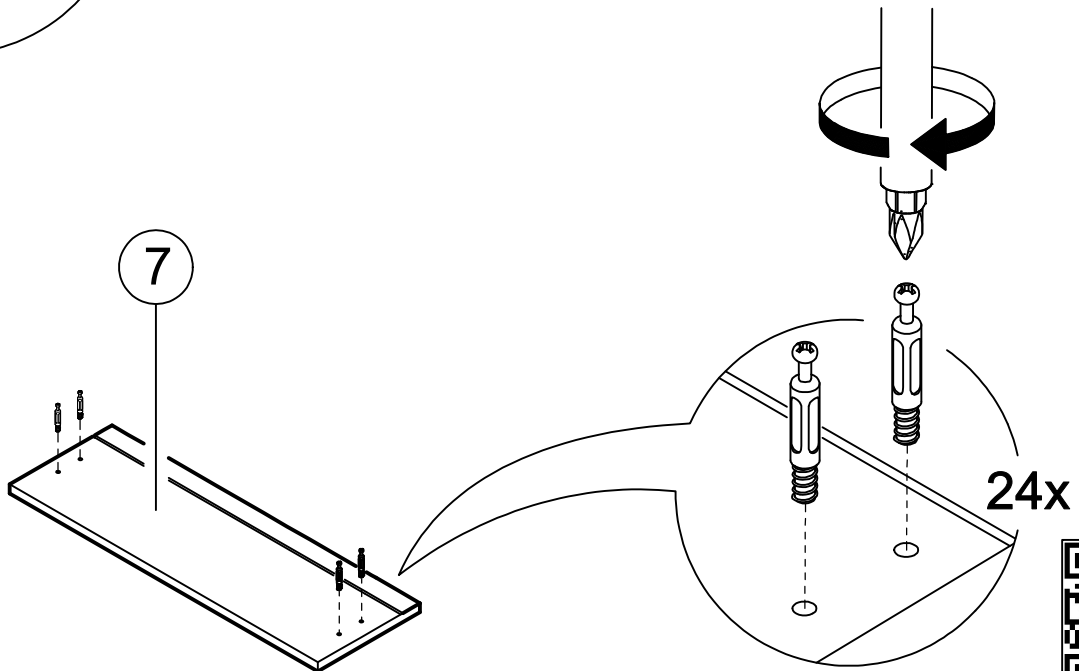

# 12

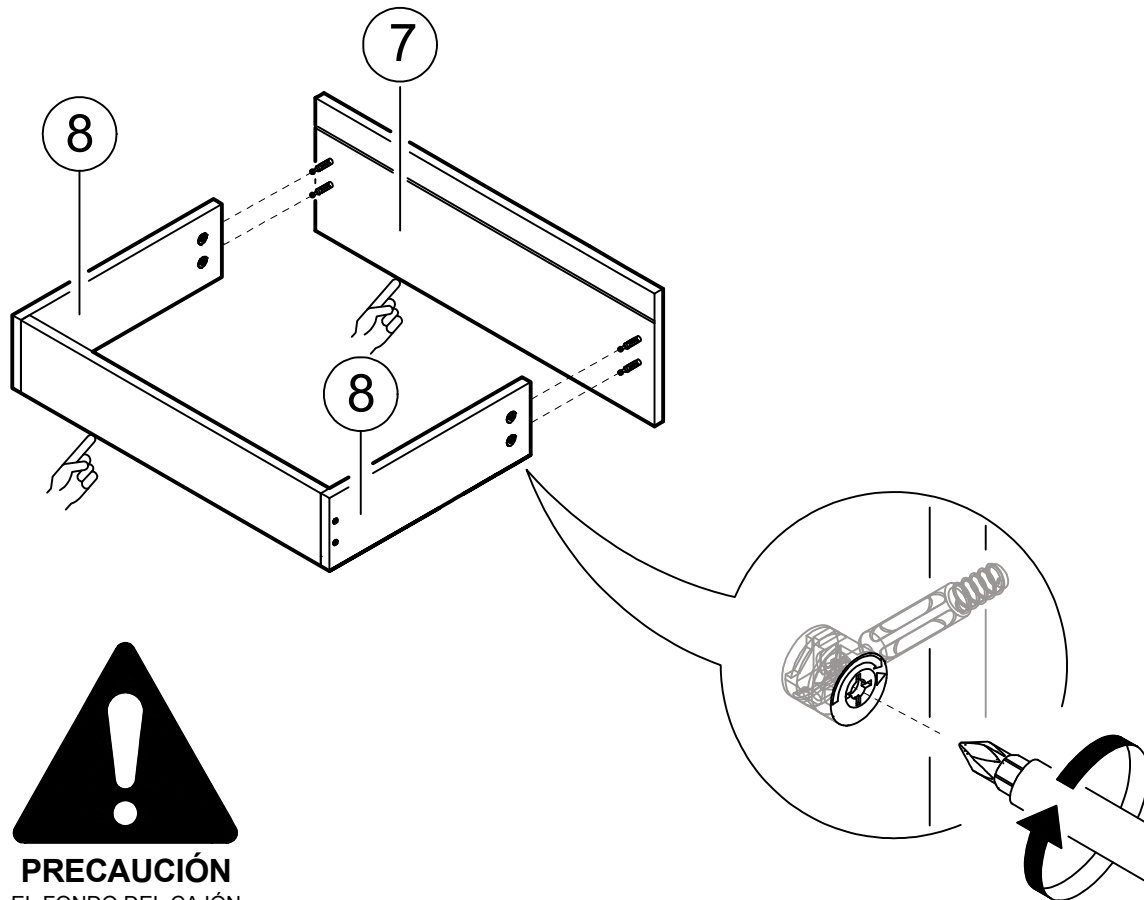

**PRECAUCIÓN**  
EL FONDO DEL CAJÓN  
SE FIJA CON EL COLOR  
HACIA ABAJO.

# 13

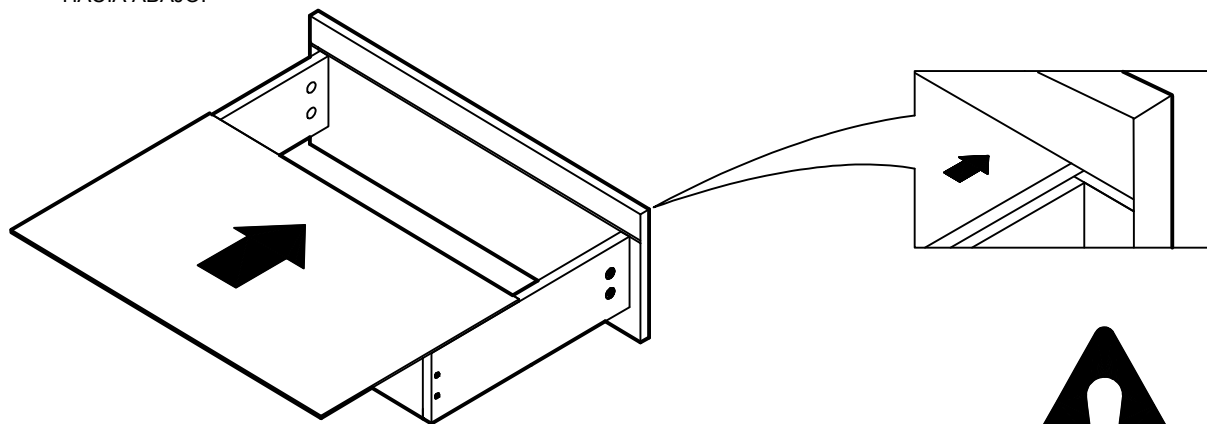

**PRECAUCIÓN**  
DE LOS 60 CLAVOS  
RESTANTES, OCUPE 10 UNID.  
PARA FIJAR CADA FONDO.

# 14

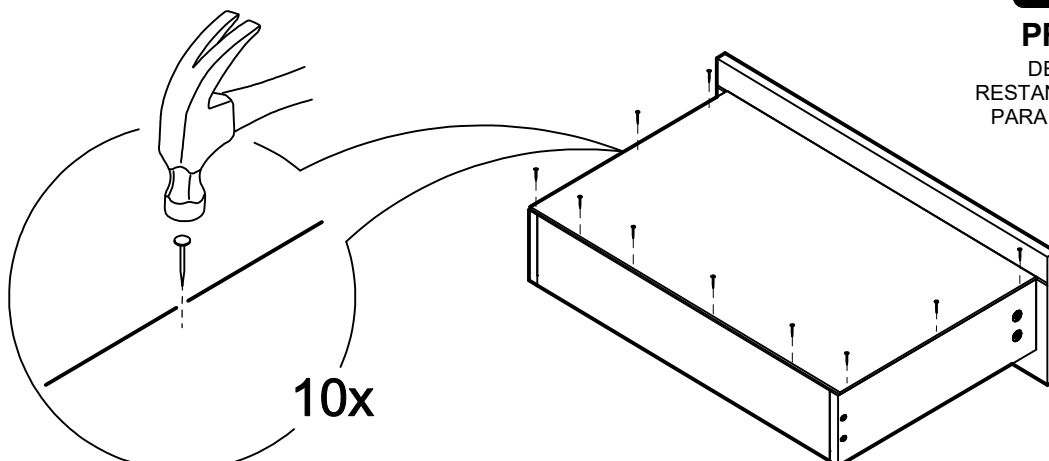

# 15

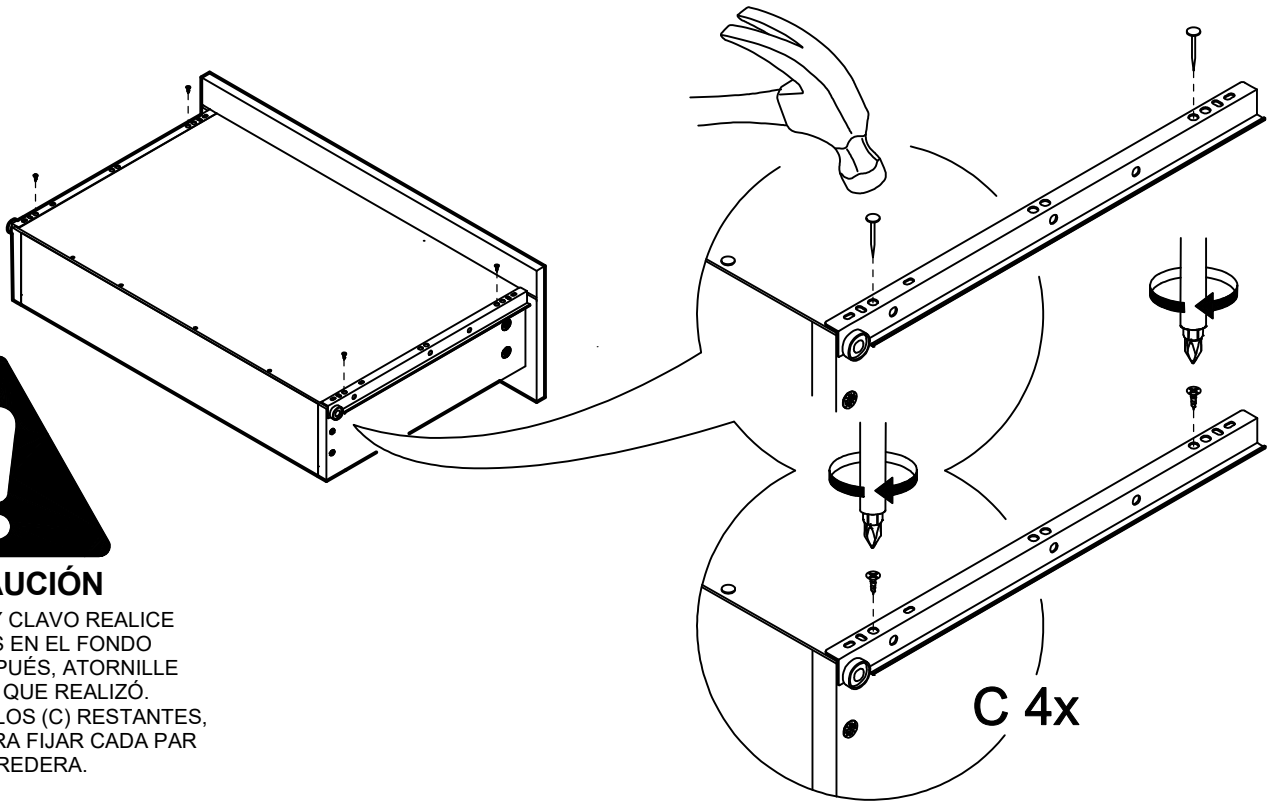

## PRECAUCIÓN

CON MARTILLO Y CLAVO REALICE  
ENCAMINADOS EN EL FONDO  
DEL CAJÓN. DESPUÉS, ATORNILLE  
EN LAS GUIAS QUE REALIZÓ.  
DEL LOS 24 TORNILLOS (C) RESTANTES,  
OCUPE 4 UNID. PARA FIJAR CADA PAR  
DE CORREDERA.

# 16

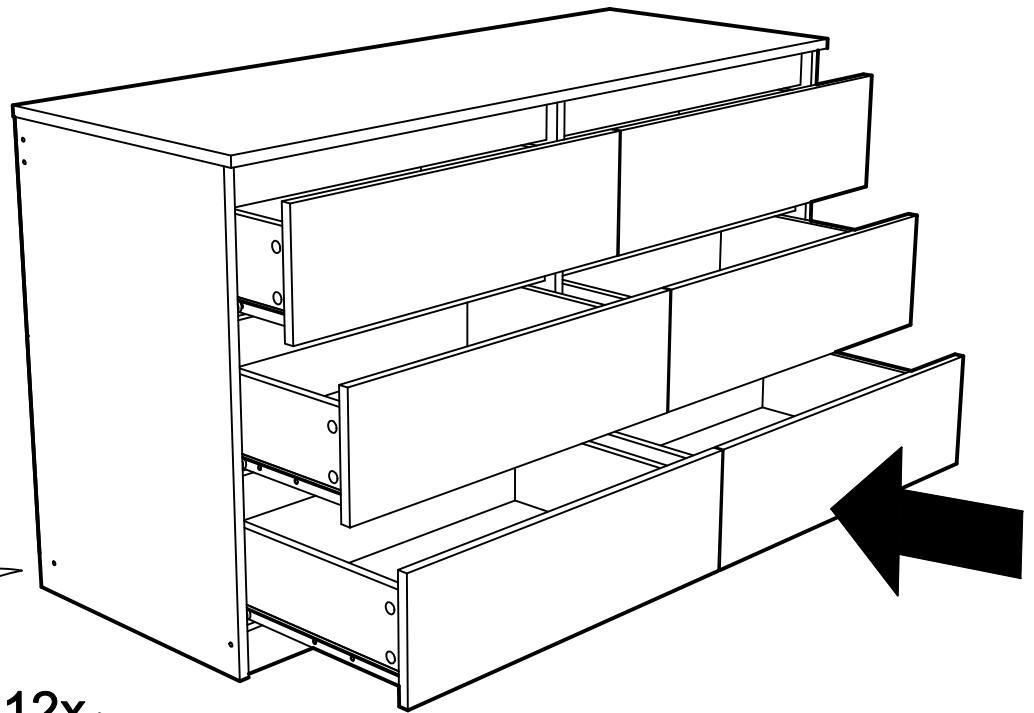

12x

12x

